

STP/IST FIXED AND VARIABLE LENGTH

INSTALLATION GUIDE

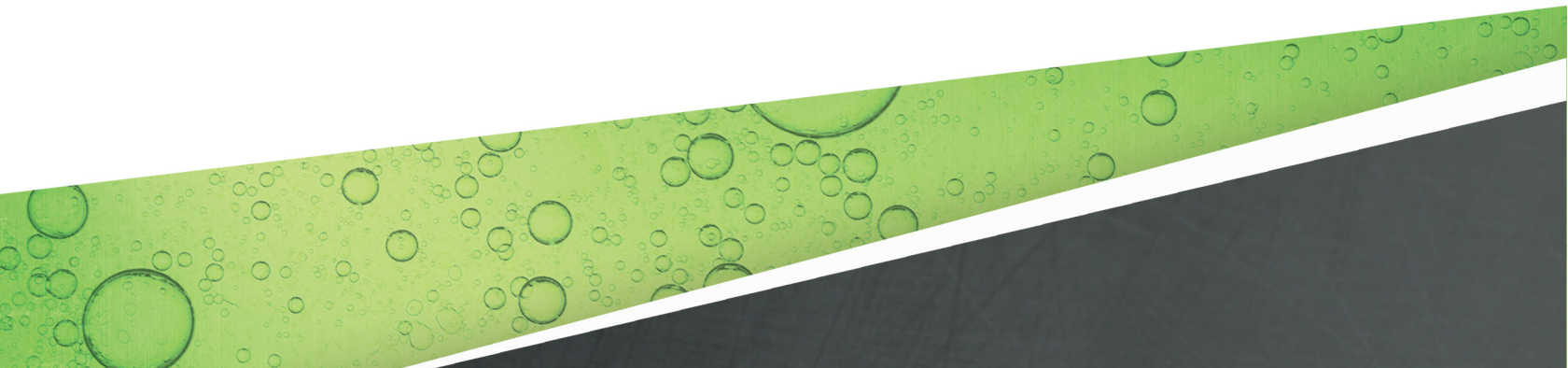

The information in this publication is provided for reference only. While every effort has been made to ensure the reliability and accuracy of the information contained in this manual at the time of printing, we recommend that you refer to "franklinfueling.com" for the most current version of this manual. All product specifications, as well as the information contained in this publication, are subject to change without notice. Franklin Fueling Systems does not assume responsibility and expressly disclaims liability for loss, damage, or expense arising out of, or in any way connected with, installation, operation, use, or maintenance by using this manual. Franklin Fueling Systems assumes no responsibility for any infringement of patents or other rights of third parties that may result from use of this manual or the products. We make no warranty of any kind with regard to this material, including, but not limited to, the implied warranties of merchantability and fitness for a particular purpose.

Copyright © 2022 Franklin Fueling Systems, LLC, Madison, WI 53718. All world rights reserved. No part of this publication may be stored in a retrieval system, transmitted, or reproduced in any way, including, but not limited to, photocopy, photograph, magnetic, or other record, without the prior written permission of Franklin Fueling Systems.

For technical assistance, please contact:

Franklin Fueling Systems
3760 Marsh Rd.
Madison, WI 53718
USA

Web: franklinfueling.com

Tel: +1 608 838 8786 • Fax: +1 608 838 6433

Tel: USA & Canada +1 800 225 9787 • Tel: UK +44 (0) 1473 243300

Tel: Mex 001 800 738 7610 • Tel: DE +49 6571 105 380 • Tel: CN +86 10 8565 4566

Loctite® is a registered trademarks of Henkel Corporation

400604005 r24

CONVENTIONS USED IN THIS MANUAL

This manual includes safety precautions and other important information presented in the following format:

NOTE: This provides helpful supplementary information.

IMPORTANT: This provides instructions to avoid damaging hardware or a potential hazard to the environment, for example: fuel leakage from equipment that could harm the environment.

▲ CAUTION: This indicates a potentially hazardous situation that could result in minor or moderate injury if not avoided. This may also be used to alert against unsafe practices.

▲ WARNING: This indicates a potentially hazardous situation that could result in severe injury or death if not avoided.

▲ DANGER: This indicates an imminently hazardous situation that will result in death if not avoided.

OPERATING PRECAUTIONS

Franklin Fueling Systems (FFS) equipment is designed to be installed in areas where volatile liquids such as gasoline and diesel fuel are present. Working in such a hazardous environment presents a risk of severe injury or death if you do not follow standard industry practices and the instructions in this manual. Before you work with or install the equipment covered in this manual, or any related equipment, read this entire manual, particularly the following precautions:

IMPORTANT: To help prevent spillage from an underground storage tank, make sure the delivery equipment is well-maintained, that there is a proper connection, and that the fill adaptor is tight. Delivery personnel should inspect delivery elbows and hoses for damage and missing parts.

▲ CAUTION: Use only original FFS parts. Substituting non-FFS parts could cause the device to fail, which could create a hazardous condition and/or harm the environment.

▲ WARNING: Follow all codes that govern how you install and service this product and the entire system. Always lock out and tag electrical circuit breakers while installing or servicing this equipment and related equipment. A potentially lethal electrical shock hazard and the possibility of an explosion or fire from a spark can result if the electrical circuit breakers are accidentally turned on while you are installing or servicing this product. Refer to this manual (and documentation for related equipment) for complete installation and safety information.

▲ WARNING: Before you enter a containment sump, check for the presence of hydrocarbon vapors. Inhaling these vapors can make you dizzy or unconscious, and if ignited, they can explode and cause serious injury or death. Containment sumps are designed to trap hazardous liquid spills and prevent environmental contamination, so they can accumulate dangerous amounts of hydrocarbon vapors. Check the atmosphere in the sump regularly while you are working in it. If vapors reach unsafe levels, exit the sump and ventilate it with fresh air before you resume working. Always have another person standing by for assistance.

▲ WARNING: Follow all federal, state, and local laws governing the installation of this product and its associated systems. When no other regulations apply, follow NFPA codes 30, 30A, and 70 from the National Fire Protection Association. Failure to follow these codes could result in severe injury, death, serious property damage, and/or environmental contamination.

▲ WARNING: Always secure the work area from moving vehicles. The equipment in this manual is usually mounted underground, so reduced visibility puts service personnel working on it in danger from moving vehicles that enter the work area. To help prevent this safety hazard, secure the area by using a service truck (or some other vehicle) to block access to the work area.

▲ DANGER: Make sure you check the installation location for potential ignition sources such as flames, sparks, radio waves, ionizing radiation, and ultrasound sonic waves. If you identify any potential ignition sources, you must make sure safety measure are implemented.

CONTENTS

INTRODUCTION	1
SAFETY	1
REQUIRED TOOLS	1
INSTALLATION	2
MOUNTING THE PMA	3
LENGTH SETTING	5
PMA WIRING	7
SECURE TO TANK	8
MANUAL PRESSURE RELIEF	12
CLAMP VALVE (CHECK VALVE CLAMP)	12
TIGHTENING STP MANIFOLD FITTINGS	12
SYPHON SYSTEMS (OPTIONAL)	12
WIRING DIAGRAM 1	13
WIRING DIAGRAM 2	14
PMA, RISER AND CHECK VALVE FOR VL AND FIXED LENGTH	16
DISCHARGE MANIFOLD ASSEMBLY	18
SYPHON CHECK VALVE	19
CONTROL BOX ASSEMBLY (STP-CBS)	19

Intentionally Blank

INTRODUCTION

SAFETY

⚠ WARNING: Do not modify the STP/IST, modifying any feature of the STP / IST can cause environmental and safety issues. FFS's submerged turbine pumps are subjected to rigorous quality control testing during assembly. Field alteration of the pumps in any way, including shortening of the column pipe and conduit, defeats these quality tests, and could result in a fuel leak or dangerous electrical contact.

⚠ WARNING: Thermal expansion can cause pressure to build up in the product lines. FFS's STP/ISTs have a built-in relief valve to release this excess line pressure back to the tank. Do not use an additional check valve unless it has the capability to relieve excess pressure back to the tank, as this could result in a buildup of abnormal pressure in the lines, causing a pipe or joint in the supply line piping to burst, and release of fuel into the environment.

⚠ WARNING: Product explosion-proof bonding surfaces should not be repaired/maintained.

IMPORTANT: To the installer, this manual MUST be left with the owner of the service station at which the equipment is being installed.

IMPORTANT: To the station owner, retain these instructions for future use and provide them to persons servicing or removing this equipment.

NOTE: Some underground storage tanks are ballasted with water during construction. DO NOT use the submersible pump to remove water from the tank. The pump is designed for use with petroleum products only, and pumping other fluids will seriously damage the unit. We do not recommend immersing the pump in water, but, if this does happen, immediately fill the tank with motor fuel after the water is removed from the tank. Severe corrosion takes place very quickly if the unit has been submerged in water and is then exposed to air. If the pump will not operate after gasoline is put into the tank, remove the extractable portion, remove the black plastic end cap from the pump motor assembly (PMA), and turn the Allen screw clockwise at the end of the PMA. This will break free the PMA from any corrosion that may be present. Reinstall the PMA end cap and the extractable section into the pump housing.

REQUIRED TOOLS

- Standard ¾" drive ratchet wrench or breaker bar (no sockets required)
- Standard flat head screwdriver
- Wire cutter and stripper
- 5/32" Allen wrench for securing set screw in telescoping pipe coupling (VL units only)
- Pipe wrench (36" minimum) for tightening 4" Riser
- ¼" hex driver with socket and ratchet wrench, or ¼" Allen wrench for attaching PMA
- Measuring tape (long enough to reach bottom of the tank from 30" to 70" above the tank)

IMPORTANT: All wiring must conform to guidelines in accordance with all federal, state, and local codes. Failure to comply with all applicable guidelines could result in an unsafe installation. Use the following table for maximum wire length to wire gauge ratios for submersible wiring:

Wire Size	Maximum Run
10 gauge	650 feet
12 gauge	400 feet
14 gauge	250 feet

INSTALLATION

The piping and underground storage tank must be installed using good standard industry practices. Listed below are several publications that can be used for reference:

- Automotive and Marine Service Station Code, NFPA 30A, Flammable and Combustible Code, NFPA 30, and National Electrical Code, NFPA 70 (NEC), National Fire Protection Association, Quincy, Mass.
- Recommended Practices for Installation of Underground Liquid Storage Systems, The Petroleum Equipment Institute, PEI / RP100, Latest Edition.
- Recommended Practices for Installation of Aboveground Storage Systems for Motor Vehicle Fueling, The Petroleum Equipment Institute, PEI/RP200, Latest Edition.
- Installation of Underground Petroleum Storage Systems, American Petroleum Institute, API Recommended Practice 1615, Latest Edition.
- Installation of ATEX approved pumps should be done in compliance with the following Standards:
 - EN 60079-14
 - EN 60079-17
 - EN 60079-19
 - VDE 0100

NOTE: ATEX approved pumps to be installed in Zone 0 (category 1) locations require SIL-1 certified motor control.

NOTE: Review the Additional Information Sheet for ATEX Compliant Installations for details (Franklin Fueling System's document 401358001).

NOTE: The manufacturing of Submersible Turbine Pump meets the National Standards of GB/T3836.1-2021 << Part 1 of Explosive Atmospheres: General Equipment Requirements>>, and GB/T3836.2-202 << Part 2 of Explosive Atmospheres: Equipment protected by flameproof type "d">>. The Explosion Proof certificate number is on the Nameplate. Explosion-proof mark: Ex db sa IIA T4 Ga/Gb

1. Fill out the Warranty Registration Card and return it to FFS.

IMPORTANT: All NPT threaded STP pipe fittings should be assembled using a non-hardening, UL classified, gasoline resistant pipe sealing compound. Fittings should be installed hand tight, and then tightened until wrench tight (without exceeding 3 turns for fittings up to and including 2" and 2 turns for larger fittings). To ensure proper installation, the joint must be pressurized and checked that there is no leakage. This check is essential and must be the specification for making sure a joint is properly assembled.

NOTE: If your STP/IST does not operate correctly or there are any questions concerning installation or service, please contact FFS.

2. Disconnect power to the submersible pump at the electrical supply box (if already installed).
3. Tag and lock out electrical circuit breakers so they are not turned on accidentally.
4. Do one of the following:
 - If installing variable length pump, continue with this section.
 - If installing fixed length pump (non-variable) with PMA mounted, go to SECURE TO TANK.
 - If installing fixed length pump (non-variable) without PMA mounted, go to MOUNTING THE PMA, and then go to SECURE TO TANK.

MOUNTING THE PMA

1. Lay packaged pump on a flat, open surface and remove the package.
2. Flatten pump packaging and lay the PMA on the end of the pump in preparation for mounting.
3. The PMA mounting hardware kit (# 152350902) is attached to the PMA packaging. It contains a gasket, a tube of grease, and four $\frac{5}{16}$ " cap screws with lockwashers.
4. Remove the two packaging ends and the protective sleeve from the PMA.
5. Apply grease provided to the inside wall of the pump motor electrical connector, and the rubber of the lead assembly connector.

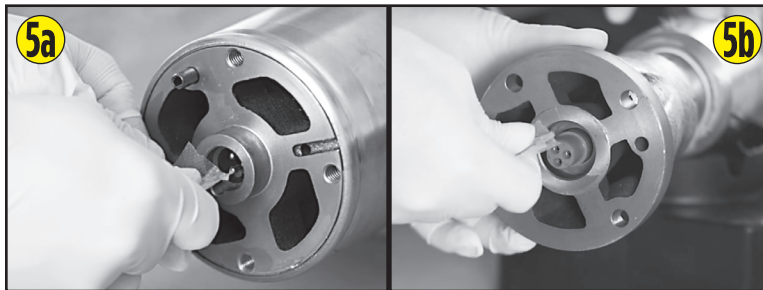

6. Place the gasket on the end of the PMA, aligning locating pin and bolt holes).

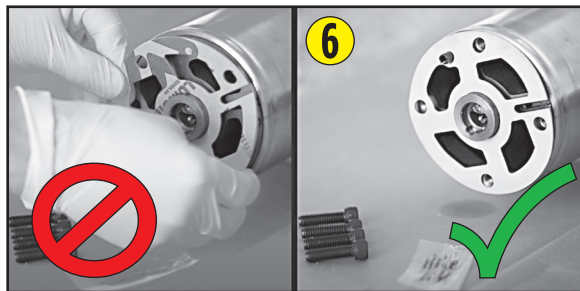

7. Mount PMA onto discharge head by aligning locating pin on PMA with hole in discharge head, assuring that the lead assembly in the motor discharge head is seated in its notched position, and that the PMA gasket is properly in place.

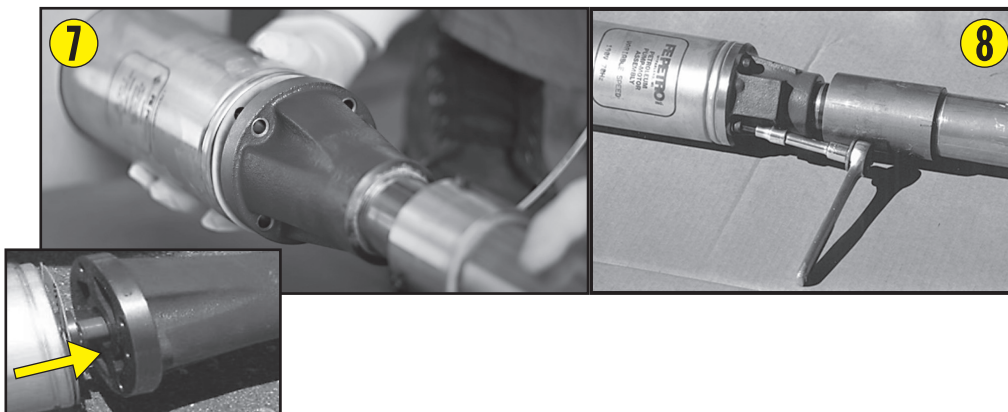

8. Tighten PMA onto discharge head using four cap screws and lock washers supplied. A cross bolt-tightening pattern is recommended for securing PMA.

▲ WARNING: The motor discharge head must not be rotated more than one full rotation in either direction. Rotation could cause damage to the electrical connections in the conduit, creating a risk of lethal electrical shock or equipment failure.

NOTE: Before assembling the PMA to the discharge casting make sure the wire lead is properly set and aligned in the discharge casting. Improper alignment could damage the wire lead or motor pins. Failure to push PMA up snug against the discharge casting before tightening cap screws, or failure to use a cross-pattern while tightening the bolts could break the discharge casting or strip the threads in the PMA.

NOTE: IST units without a VS4 suffix and STP units with a VS2 suffix can only be electrically connected to an IST-VFC or MagVFC.

NOTE: STP or IST units with a VS4 suffix can only be electrically connected to a *MagVFC* or *EcoVFC*. Unlike FFS's standard pumps, the following pumps cannot be interchanged with competitive models:

- The variable speed PMA VS2 (which is part of IST units without the VS4 suffix or the STP units suffixed with VS2)
 - The PMA VS4 (which is part of the IST and STP units with the VS4 suffix)
9. Apply a non-hardening, UL classified, gasoline-resistant pipe sealing compound to the riser pipe threads, if not already installed.

IMPORTANT: Failure to use a proper thread sealing compound could result in a lack of seal where the riser threads into the tank opening, making it impossible to perform a tank-tightness test. This may also create a potential site for fuel to leak into the environment and/or the containment sump.

10. Slide riser over the PMA and tighten into manifold threads. Maximum riser size is found by taking the grade to tank mounting thread measurement and subtracting the manifold height and clearance (6" clearance recommended).

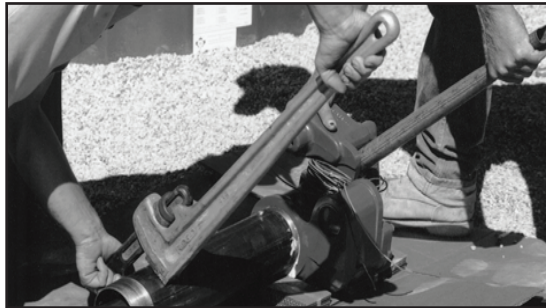

11. Riser material required for pump is 4.5" outside diameter with a .188" wall. Minimum riser length supplied by FFS is 7".

Example:

Grade to tank mounting threads (bury depth)	48"
Minus manifold height without leak detector (w/ leak detector height = 12.50)	-11"
Minus 6" for top clearance (2" minimum)	-6"
= Maximum riser size	31"

LENGTH SETTING

1. Cut wire tie(s) securing the motor wire at the top of the pump; lay the wires out above the pump head so that wires can feed through conduit freely when setting length.

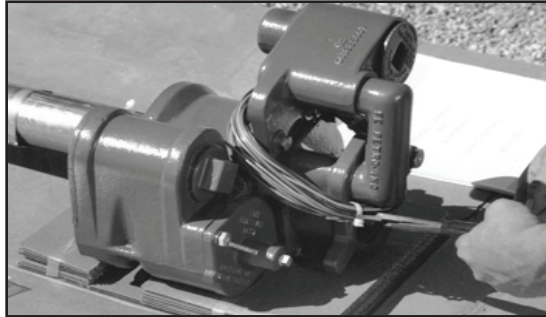

IMPORTANT: Failure to cut wire ties prior to setting pump length could result in damage to electrical motor wires, presenting a risk of lethal electrical shock or equipment failure.

2. Measure from the bottom of the tank to the top of tank mounting threads. Subtract the distance for clearance between the PMA and the bottom of the tank (6" recommended). This is the length to which the pump should be extracted, measured from the bottom of the riser threads to the bottom of the motor end bell.

NOTE: 6" clearance provides a 5" clearance from the pump motor end bell to the bottom of the tank once the riser is screwed into tank mounting threads.

Tank + thread measurement	96"
Distance from bottom (5") + riser thread engagement (1")	-6"
<hr/>	
= Length (bottom of riser to end bell)	90"

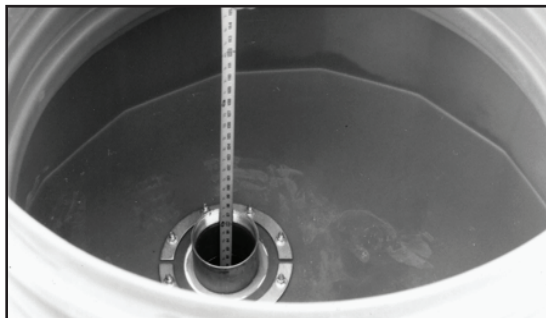

3. Hold the manifold securely to the surface to prevent damage while setting length.

To allow movement of the telescoping pipe, verify that none of the pipe coupling setscrews are in contact with the pipe. Lay a tape measure out to accurately measure the distance from the bottom of the riser to the bottom of the pump motor end bell.

4. Grasp the pump just above the PMA and pull firmly, extending to the length required).

NOTE: Make sure the electrical conduit wires at the top of the discharge manifold are not damaged during length setting. If the column pipe is extended beyond the desired length, have a second person retract conduit wires as the column pipe is shortened. This helps prevent damage to the conduit wires.



IMPORTANT: The motor discharge head must not be rotated more than one full rotation in either direction. Rotating could cause damage to the electrical motor wires, presenting a risk of potentially lethal electrical shock or equipment failure.

NOTE: O-ring seals inside the locking coupling may have sealed to the column pipe during shipping. Spin the motor discharge head slightly (not more than one full rotation) while pulling to loosen the O-ring seals.

5. Once the length is correct, lock the STP length by tightening all three coupling setscrews. Tighten the setscrews finger-tight, making sure they come into contact with the pipe.

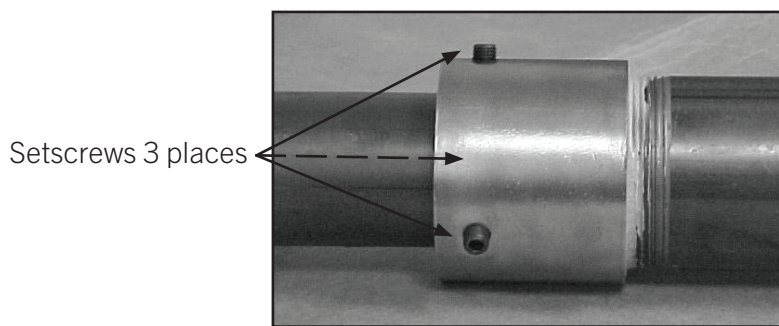

NOTE: Loctite® 243 thread locker must be used on all ATEX approved pumps.

6. Tighten each setscrew an additional full turn minimum. The head of the setscrews should be flush or below flush with the outer surface of the coupling.

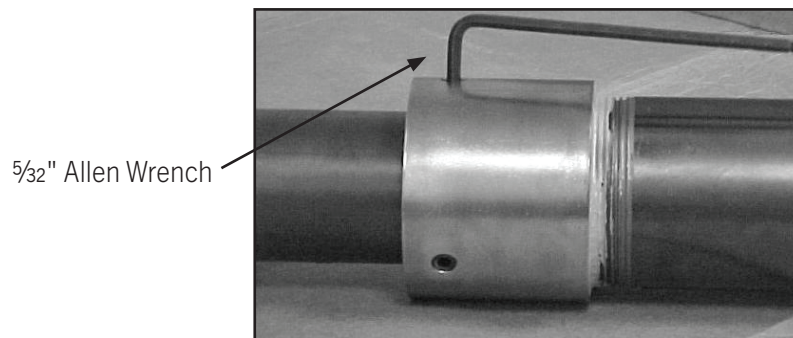

NOTE: Failure to properly tighten the coupling setscrews at this stage could present a risk of death, serious bodily injury and/or equipment damage due to movement of pipes during installation.

PMA WIRING

1. Measure 6" of wire from the discharge manifold. Cut off excess wire and discard.



2. Place the three wires through the plug assembly (from hardware pack p/n 400301XXX).



3. Using the screwdriver slide the contractor's plug into its seat in the discharge manifold. Tighten the screw(s) in the contractor plug to secure it in place.



4. Strip the wire insulation back approximately $\frac{3}{8}$ " on the three motor leads. Using the wire nuts or terminal blocks supplied (from hardware pack p/n 400301XXX) connect to the wires from the electrical connector orange to orange, black to black, and red to red.

NOTE: Terminal blocks are provided for wire connections on ATEX approved pumps. For terminal blocks, strip 5mm insulation from the end of the wires. Torques terminal screws to 0.4 - 0.45 Nm.

5. Coil the wires and push into the discharge manifold cavity using care to ensure wires are not damaged on discharge manifold threads.



IMPORTANT: Damage to the electrical conduit wires creates a risk of lethal electrical shock and equipment failure. Do NOT use equipment if electrical wires have been damaged. Contact FFS for assistance.

6. Tighten the discharge head cover (from hardware pack p/n 400301XXX) in place using a $\frac{3}{4}$ " ratchet or breaker bar.

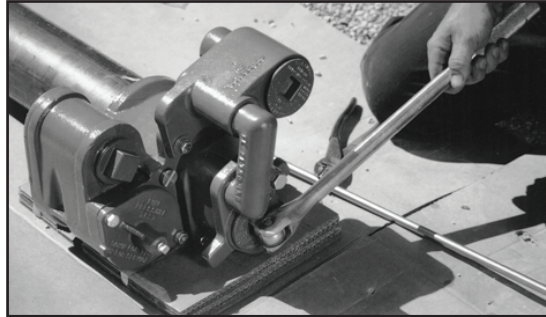

SECURE TO TANK

NOTE: The bottom end-bell of the PMA is not designed to support the weight of the entire pump. Resting or dropping the pump on this end-bell may damage the plastic end-bell and the plastic pump components inside. This type of damage is not considered a manufacturing defect under FFS's warranty.

1. Measure the pump, from the bottom of the threaded riser to the bottom of the pump-motor, and compare this to the tank measurement, measured from the mounting flange to the inside of tank bottom. The STP/IST and riser are sized to place the intake (at the bottom of the pump-motor) approximately 5 inches off the bottom of the tank.

If the difference between the bottom of the pump motor and the bottom of the tank is more than 6 inches or less than 4 inches, verify that this is the correct pump for this tank installation. If it is not the correct pump and is outside the above specifications, contact FFS.

2. Apply a non-hardening, UL classified, gasoline-resistant pipe sealing compound to the riser pipe threads.

IMPORTANT: In order to perform a tank-tightness test, make sure you use a thread sealing compound to help ensure a seal where the riser threads into the tank opening. A lack of seal may also create a place for fuel to leak into the environment and/or the containment sump.

3. Carefully lower the unit into the tank, and engage the threaded riser of the pump into the threaded flange on the tank. Tighten the riser into the tank using a large pipe wrench until a water/air tight joint has been made. Do this by turning in the tightening (clock-wise) direction only.

Turning the pump in the loosening direction during the tightening process may scrape away the thread sealing compound, making it impossible to perform a tank-tightness test. This may also create a potential site for fuel to leak into the environment and/or the containment sump.

4. Connect the supply line piping to the discharge port in the discharge manifold assembly. The discharge port is the 2-inch NPT vertical opening.

5. Connect the electrical conduit with approved fittings per NFPA 30, NFPA 30A, and NFPA 70 to the junction box.
6. Remove the junction box cover (see Figure 15), and remove the compression seal (contractors plug) by loosening the screw(s) (do not remove screw). A four hole compression seal (contractors plug) is provided on all units,

On single phase units, there are two power wires, one ground wire and a blank (with celcon rod supplied to fill forth hole). For three phase units, there are three power wires and one ground wire.
7. Verify that the power is still OFF at the supply box.
8. Pull wires from power supply into the junction box and feed through the compression seal (contractors plug).
9. Replace the compression seal and tighten into place securely. All wiring must be done in accordance with the National Electrical Code (NEC) or European Norm (EN) and any other local, state, or federal regulations required.

⚠ CAUTION: The compression seal (contractors plug) is not intended to replace the vapor explosion seals required by the NEC. All materials used between the power supply box and the pump junction box must be gasoline and oil resistant. Failure to comply with all applicable codes, could result in an unsafe installation.

10. Do one of the following, according to the type of unit:
 - SINGLE PHASE UNITS: Connect the ground wire to the lug in the junction box; using the wire nuts or terminal block supplied (from hardware pack p/n 400301XXX) connect the wires from the power supply to the orange and black wires in the junction box. A capacitor is required and color-coding is not necessary.
 - THREE PHASE UNITS (except IST or STP units with VS2 or VS4 suffix): Connect the ground wire to the lug in the junction box. Connect any three wires from the pump to any three wires from the three-phase power source using the wire nuts or terminal block supplied (from hardware pack p/n 400301XXX). Capacitors are not needed for three phase units. Install a pressure gauge in the line test port (see Figure 15), turn on the pump, and read the pressure gauge. Turn off the pump at the power supply, and change the connection of any two wires at the pump. Turn the pump back on and read the pressure gauge again. The electrical connection that gives the higher reading on the pressure gauge is the correct one.
 - IST UNITS or STP units with a VS2 or VS4 suffix: Connect the ground wire coming from indoors to the ground lug in the junction box. Connect any three wires from the pump connector assembly to the three power wires coming from the Variable Frequency Controller (VFC). Capacitors are not needed for these units. Detailed installation instructions for the VFC should be referenced when connecting the VFC. These are supplied with the VFC.

NOTE: Terminal blocks are provided for wire connections on ATEX approved pumps. For terminal blocks, strip 5 mm insulation from the end of the wires. Torques terminal screws to 0.4 - 0.45 Nm.

⚠ WARNING: Not installing a ground wire increases the risk of lethal electric shock and equipment failure. All holes of the compression seal (contractors plug) must be filled with wires or a celcon rod to enable it to seal.

11. Replace the junction box cover and tighten securely.

⚠ CAUTION: The pump discharge manifold has two labeled ports: one for the syphon system and one for the tank. A piston leak detector must be vented to the tank port (lower port) only. Do not connect a piston leak detector to the syphon port because this will make the leak detector inoperative, resulting in an increased risk of contamination of the environment.

12. Connect power to the submersible pump at the electrical supply box.

13. Test proper operation by dispensing product into calibration can.

14. Turn off the dispenser switch. Feel the submersible pump to make sure that the pump has stopped running.

NOTE: If the pump does not turn off when the dispenser switch is turned off, this may indicate an electrical problem in the dispenser or other wiring error or malfunction. Call this to the immediate attention of a qualified electrician.

15. Visually check for leaks on the manifold head during pump operation and after.

16. Install a pressure gauge in the line test port to ensure that the STP/IST is providing proper line pressure.

17. Turn on the STP/IST. While running, the pressure should be above 24 psi (1.65 bar). PMA size will affect psi.

18. Turn off the STP/IST and verify that the line pressure is holding.

19. Remove the pressure gauge and replace the plug.

20. Turn on the STP/IST and, again, visually check for any leaks.

⚠ CAUTION: Product operators should be trained in explosion protection.

⚠ WARNING: The product installation and use should meet the requirements of GB/T3836.15 standard, the inspection and maintenance should meet the requirements GB/T3836.16, the product overhauls should meet the requirements of GB3836.13.

Approximate STP/IST Specifications

Model	Description	Operating Pressure (PSI)	PMA Length (in)	S.F. Amps	Locked Rotor Amps	Winding Resistance		
						R-B	R-O	B-O
STP33*	208/230 V, 60 Hz, 1 ph	27	16	3.1	11	27	19	8
STP75*	208/230 V, 60 Hz, 1 ph	30	18.25	6.1	27	20	17	3
STP150*	208/230 V, 60 Hz, 1 ph	32	21	10.5	39	15	13	2
STPH150*	208/230 V, 60 Hz, 1 ph	45	21.75	10.5	39	15	13	2
STP200+	208/230 V, 60 Hz, 1 ph	36	23.75	11.4	41	4.6	3	1.8
STPH200+	208/230 V, 60 Hz, 1 ph	46	24.5	11.4	41	4.6	3	1.8
STP75B++	200/250 V, 50 Hz, 1 ph	37	20.5	5.6	23	27	23	4
STP150B++	200/250 V, 50 Hz, 1 ph	38	22.75	8.8	28	16	13	3
STPH150B++	200/250 V, 50 Hz, 1 ph	48	23.25	8.8	28	16	13	3
STP200B‡	200/250 V, 50 Hz, 1 ph	37	25.75	9.5	37	5.5	3.5	2
STPH200B‡	200/250 V, 50 Hz, 1 ph	44	26.25	9.5	37	5.5	3.5	2
STP75C	380-415 V, 50 Hz, 3 ph**	37	19.75	2.1	10	29	29	29
STP150C	380-415 V, 50 Hz, 3 ph**	38	21.75	3.0	14	14	14	14
STPH150C	380-415 V, 50 Hz, 3 ph**	48	22	3.0	14	14	14	14
STP200C	380-415 V, 50 Hz, 3 ph**	37	23.5	4.1	23	11.6	11.6	11.6
STPH200C	380-415 V, 50 Hz, 3 ph**	44	24	4.1	23	11.6	11.6	11.6
IST/STPVS2^	190 V, 70 Hz, 3 ph†	24-42	20	6.7	N/A	2.5	2.5	2.5
ISTVS4/STPVS4^^	190 V, 70 Hz, 3 ph†	24-42	25	14.4	N/A	1.2	1.2	1.2

Symbols:

- * Use a 15 μ F, 370 V, single phase, 60 Hz capacitor
- + Use a 40 μ F, 370 V, single phase, 60 Hz capacitor
- ++ Use a 15 μ F, 440 V, single phase, 50 Hz capacitor
- ‡ Use a 40 μ F, 440 V, single phase, 50 Hz capacitor
- † 190 V, 70 Hz, 3 ph power to variable speed units is output from IST-VFC or MagVFC only (VFC's are powered by 200-250 V, 50 or 60 Hz, single or 3 phase input)
- ^ Use with EcoVFC or MagVFC controller only, No Capacitor
- ^^ Use with Mag/EcoVFC controller only, No Capacitor (3 phase input is required for full VS4 output))
- ** No capacitor is used with 3 phase pump motor assemblies

NOTE: The models listed in the table above may contain (ANZ) for ANZEX certified pumps, or either (ATXF) or (ATXF1)ATEX certified pumps.

FFS's STPs are designed for use with motor fuels and are UL listed for blend concentrations of:

Standard Models	AG (Alcohol/Gasoline) Models
0% - 10% ethanol with gasoline	0% - 85% ethanol with gasoline
20% MTBE with 80% gasoline	20% MTBE with 80% gasoline
20% ETBE with 80% gasoline	20% ETBE with 80% gasoline
17% TAME with 83% gasoline	17% TAME with 83% gasoline
100% Diesel	0-20% BioDiesel Blend or 100% Biodiesel

NOTE: Diesel, fuel oil, avgas, jet fuel, or kerosene may also be used with our PMAs. The maximum liquid viscosity for a product is 70 S.S.U. at 60° F.

NOTE: Using our PMA in liquids other than those mentioned above has not been tested. The reaction of other liquids with seals and wetted surfaces of the pump is unknown. A hazardous situation may result from using other liquids with our pump.

MANUAL PRESSURE RELIEF

The manual line pressure relief is in the center of the stationary manifold under a brass cap. You must relieve the pressure in the piping when you perform maintenance or troubleshooting.

Remove the brass cap at the top of the stationary manifold, and turn the pressure relief screw counter-clockwise until you reach the screw's retaining ring (about 4 turns). This allows the pressure in the piping system to bleed back to the storage tank. Next, turn the screw clockwise to its original position to close the path. (Do not over tighten.) Replace the brass cap. Line side pressure is now relieved, and maintenance or troubleshooting can be performed.

CLAMP VALVE (CHECK VALVE CLAMP)

The clamp valve is directly above the check valve inside the stationary manifold of the submerged pump. It consists of a lead screw with a sealing disk attached. The head of the screw is accessible by removing the ¼" line test port pipe plug on the check valve cover of the STP/IST.

NOTE: The cavity under the ¼" pipe plug is at full pump pressure and product will be released through this opening. If the pump is equipped with a manual pressure relief, use it to relieve line pressure prior to removing the plug.

For normal operation, rotate the clamp valve counter-clockwise where a star washer locks it in place. Be sure to replace the ¼" pipe plug. During a line test, the clamp valve should be rotated fully clockwise, where the sealing disk secures against the check valve. This blocks the pressure relief valve in the check valve so it does not relieve line pressure back to the tank.

TIGHTENING STP MANIFOLD FITTINGS

FFS recommends that NPT threaded STP pipe fittings should be assembled using a non-hardening, UL classified, gasoline resistant pipe sealing compound. Fittings should be installed hand tight and then tightened until wrench tight without exceeding 3 turns for fittings up to and including 2" and 2 turns for larger fittings. To ensure proper installation, the joint must be pressurized and checked that there is no leakage. This check is essential and must be the specification for making sure a joint is properly assembled.

SYPHON SYSTEMS (OPTIONAL)

Syphoned tanks should be of the same diameter with tank bottoms located on the same horizontal plane. Using tanks of different diameter, or installing the bottoms of the tanks on different horizontal planes may create a potential site for fuel to leak into the environment and/or the containment sump due to overflow of the tank(s).

Some jurisdictions allow two or more tanks of the same product grade to be manifolded together with a syphon loop. These systems usually have a single submersible pump, and the syphoning action keeps the tanks level while pumping out of only one tank. All FFS submersible pumps have syphoning capability built into the pump. Syphon check valves, however (if required), must be ordered separately. The outlet of the syphon check valve should be connected with a line to the highest spot in the syphon loop. At this point the pump creates a vacuum of 20-28" Hg.

When correctly installed, the syphon action between the tanks will continue whether the pump is running or not, as long as the product level in the tanks is higher than the bottom of the syphon loop vertical piping. The function of the STP/IST in the syphon system is merely to prime the syphon line, removing the air and allowing the syphon to take place.

NOTE: The syphon port on FFS submersible pumps was designed to be connected to the syphon piping between tanks. Using the vacuum port (syphon port) for other purposes may create complications with the pump's ability to draw a vacuum because of excessive foreign materials being drawn into pump components.

NOTE: A fuel filter, between the syphon check valve and the syphon loop, may be useful to help eliminate debris from entering the syphon check valve. Debris can keep a syphon check valve from operating properly. Be sure to use a fuel filter, which is compatible with the application.

WIRING DIAGRAM 1

⚠ WARNING: The Lockout switch is not a substitute for proper lock-out and tag-out of electrical circuit breakers while installing or servicing this equipment or related equipment.

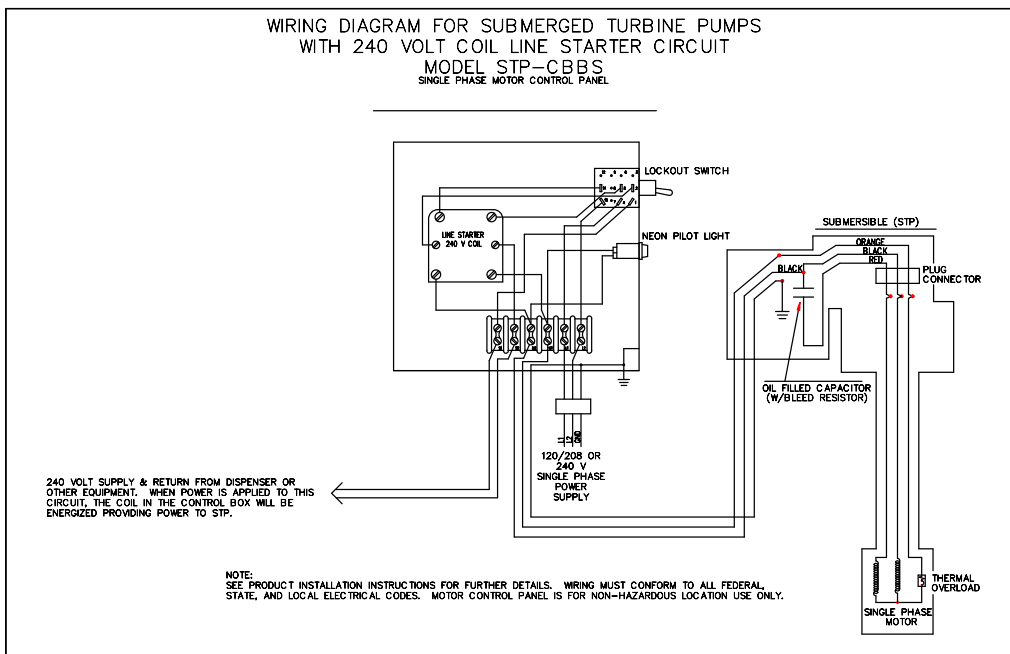
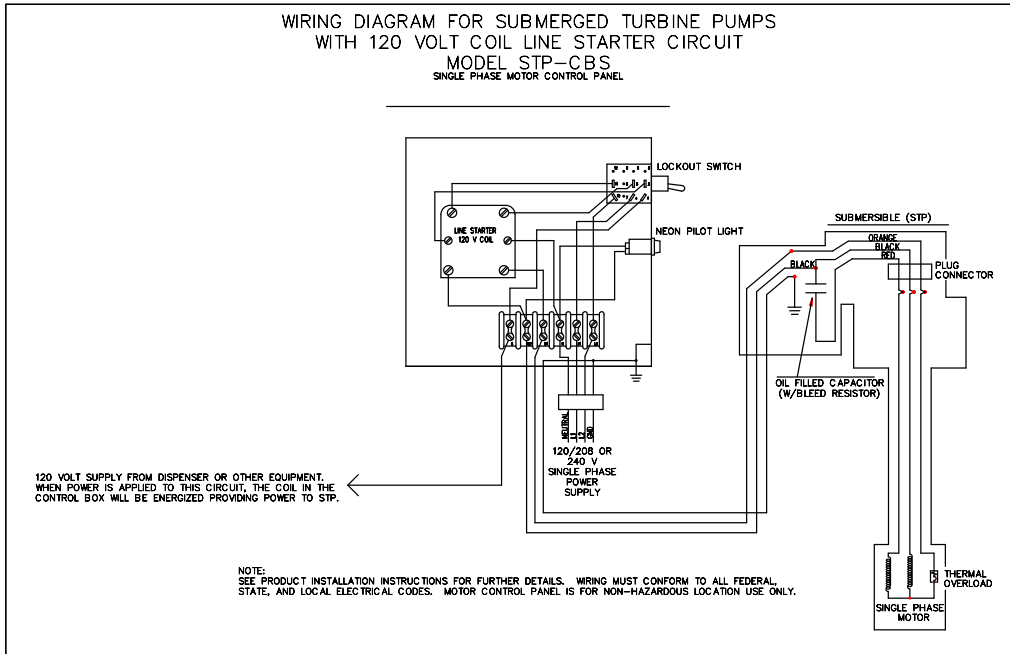

WIRING DIAGRAM 2

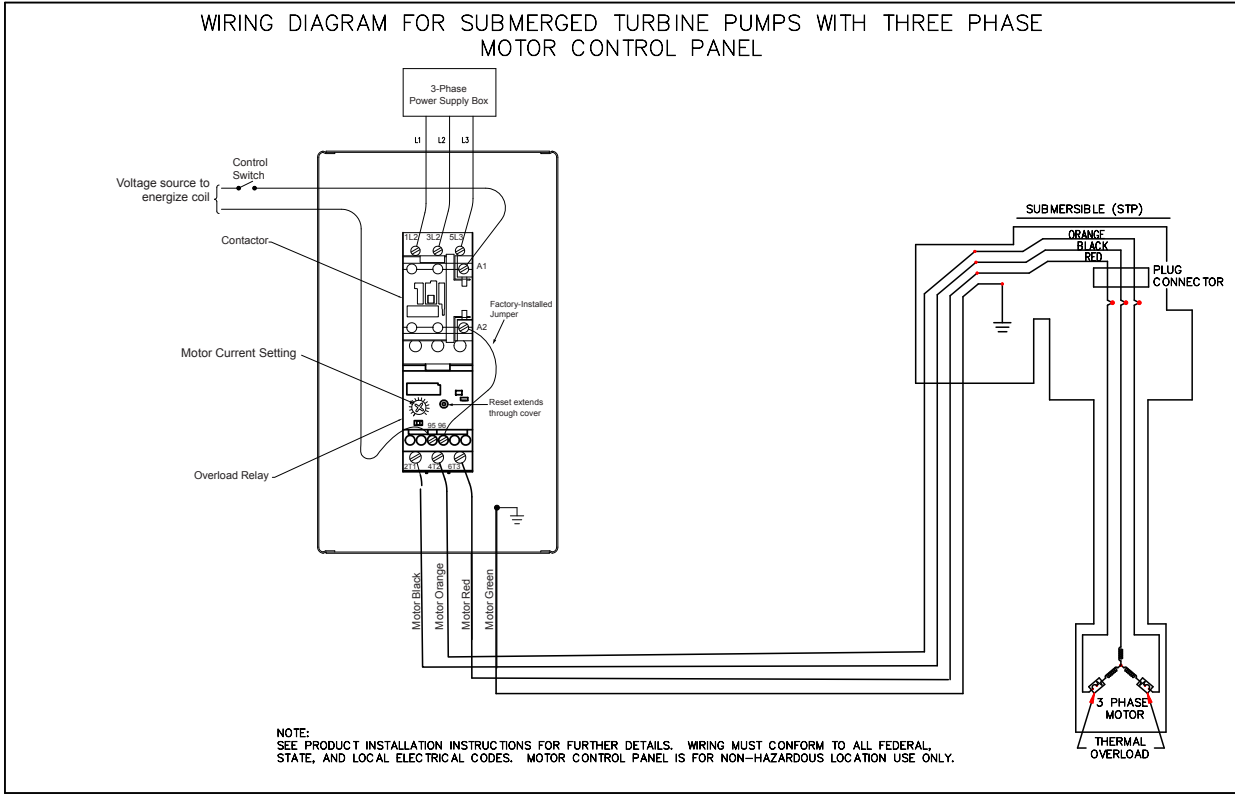

Intentionally Blank

PMA, RISER AND CHECK VALVE FOR VL AND FIXED LENGTH

Item	Model	Description	Qty
1	400125001	3/16" x 1 5/8" spiral pin	1
2	400615001	Manual relief plug (400615002 AG compatible)	1
3	400211114	O-ring, MPR plug	1
4	400627001	Retaining ring, MPR	1
5	400616001	Manual relief screw (400616002 AG Compatible)	1
6	400333012	Relief screw, top O-ring	1
7	400333007	Relief screw, bottom O-ring	1
8	400628901	Manual relief plug assembly, includes items #2 and #3 (400628902 AG compatible)	1
9	400629901	Manual relief screw assembly, includes items #4, #5, #6, and #7 (400629902 AG compatible)	1
10	400259001	1/4" NPT pipe plug, may be purchased locally	3
	403499001	1/4" NPT pipe plug, may be purchased locally (stainless steel, for AP models)	
11	400137937	Syphon check valve	-
12	400221930	Discharge manifold, includes #1, #8, #9, and two #10	1
	400221931	Discharge manifold (includes item #1, #8, #9, and #10) (for AP models)	-
13	151213930	156" lead assembly	1
	151213932	240" lead assembly	
14	Purchase locally	Stationary vapor tube, 3/8 OD x 7/20 WT	-
15	4001689XX (XX = length)	Riser, 4 1/2" OD x 3/16" WT steel tubing (consult factory for lead times for 31"-60" lengths) 7" - 19" 20" - 30" 31" - 49" 50" - 60"	1
	4035229XX (XX = length)	Riser, 4 1/2" OD x 4.12" ID (stainless steel, for AP models) consult factory for lead time 7" - 19" 20" - 30" 31" - 49" 50" - 60"	
16	Purchase locally	1/2" steel banding (stainless steel for AP models)	-
17	400600002	5/16-24 x 7/16" set screw for variable lengths only	3
	403432002	5/16-24 x 7/16" set screw for VL models only (stainless steel, for AP models)	-
18	400333015	Lead assembly O-ring	4
19	400264009	5/16-18 x 1 1/8" socket head cap screw, may be purchased locally	4
	403506001	5/16-18 x 1 1/8" socket head cap screw, may be purchased locally (stainless steel, for AP models)	
20	400263004	5/16" high-collar lock washer, may be purchased locally	1
	403505001	5/16" high-collar lock washer, may be purchased locally (stainless steel, for AP models)	
21	403403001	PMA gasket (403403002 AG/AP compatible)	1
22	PMA XXX	Pump motor assembly, includes item #30 (XXX indicates options and horsepower)	1
23	400981001	3/8-16 x 1" Hex head screw	2
	403504001	3/8-16 x 1" Hex head screw (stainless steel, for AP models)	
24	400285002	3/8" standard lock washer, may be purchased locally	2
	1117703	3/8" standard lock washer (stainless steel, for AP models)	
25	400197930	Manifold assembly cover, includes #10, #26, two #23, and two #24	1
	400197931	Manifold Assembly Cover (includes item #10, #23, #24, and #26 for AP models)	
26	400333238	O-ring, manifold cover (AG compatible)	1
27	400147930	Clamp valve assembly (AG compatible)	1
28	400174930	Check valve spring	1
29	400988931	Standard check valve, includes item #26 (400988934 AG compatible)	1
	400988932	Model R check valve, (for Veeder-Root™ PLLD) includes item #26 (400988935 AG compatible)	
	400988933	Model W check valve, (for Red Jacket PPM4000) includes item #26 (400988936 AG compatible)	
	402459931	Model 65 psi check valve, AG compatible (for secondary manifolded STPs with Veeder-Root™ PLLD)	
30	152350902	PMA hardware pack, includes #21, and four #19 and #20 (152350904 AG compatible)	-
--	400216905	AG compatible O-ring kit, includes items #3, #6, #7, and #26 on this page and items #2, #10, #13, #19 and #20 on the Discharge Manifold Assembly page	-

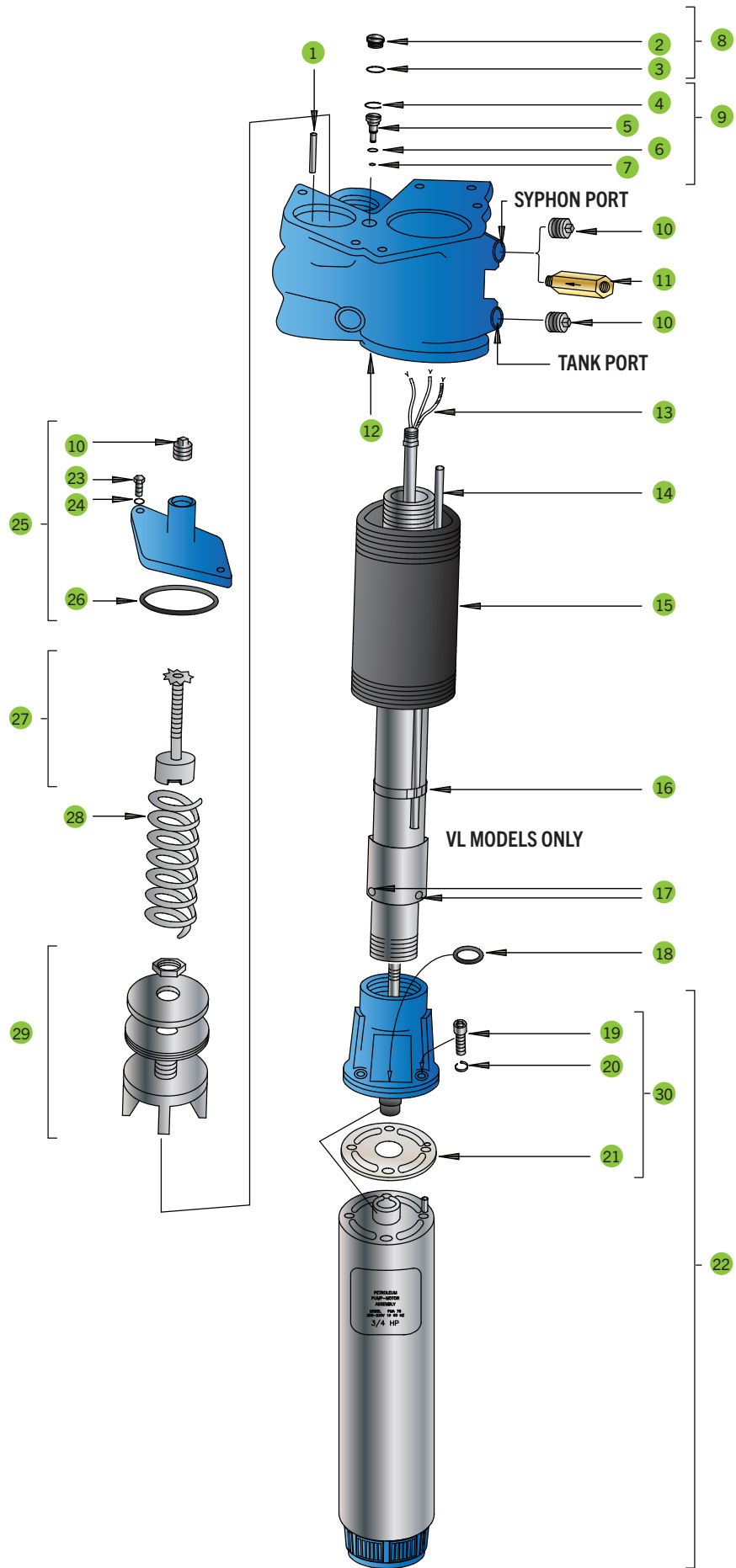

DISCHARGE MANIFOLD ASSEMBLY

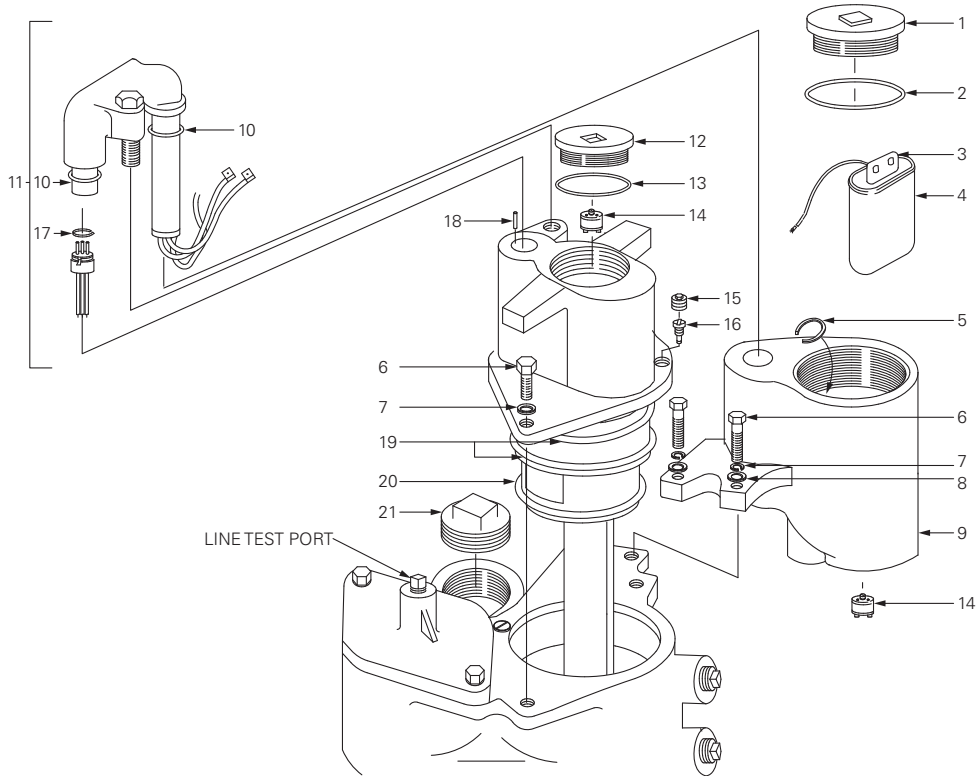

Item	Model	Description	Qty.
1	400192930	Junction box cover, includes item #2	1
	4001 92931	Junction box cover, includes item #2 (for AP models)	
2	400210233	O-ring, junction box cover	1
3	400655001	Capacitor boot	1
4	400170931	Capacitor assembly for 1/3 to 1 1/2 hp, 60 Hz, 15µfd, 370 Volt single-phase; includes one black lead	1
	400170934	Capacitor assembly for 2 hp, fixed speed, 60 Hz, 40µfd, 370 Volt single-phase; includes one black lead	
5	400257001	Retaining ring, Female connector	1
6	400258002	3/8-16 x 1 1/4" Hex head bolt, may be purchased locally	4
	602011016	3/8-16 x 1 1/4" Hex head bolt (stainless steel, for AP models)	
7	400285002	3/8 standard lock washer, may be purchased locally	4
	1117703	3/8 standard lock washer (stainless steel, for AP models)	
8	400280001	3/8 standard flat washer, may be purchased locally	2
	403500001	3/8 standard flat washer (stainless steel, for AP models)	
9	400651930	Junction box assembly, includes two #6, #7, and #8	1
	400651931	Junction box assembly (includes item #6, #7, and #8, for AP models)	
10	400210212	O-ring, Female connector	2
11	400200930	Wire connector kit, includes male/female connectors, two #10, one #5, and #18	1
	400200931	Wire connector kit, includes male/female connectors, two #10, one #5, and #18 (for AP models)	
12	400589930	Cover, includes item #13	1
	400589931	Cover, includes item #13 (for AP models)	
13	400210229	O-ring	1
14	400236903	Contractor's plug, 4-wire	2
15	400259002	3/8" NPT pipe plug, may be purchased locally (403499002, stainless steel for AP models)	1
16	400562901	Syphon jet assembly (400562903 AG compatible)	1
17	400249001	Retaining ring	1
18	400250002	1/8" dia. x 1/2" roll pin	1
19	400333343	AG compatible O-ring, extractable (upper, large)	2
20	400333340	AG compatible O-ring, extractable (lower)	1
21	400259005	2" NPT square head plug	1
	403499003	2" NPT square head plug (stainless steel, for AP models)	

SYPHON CHECK VALVE

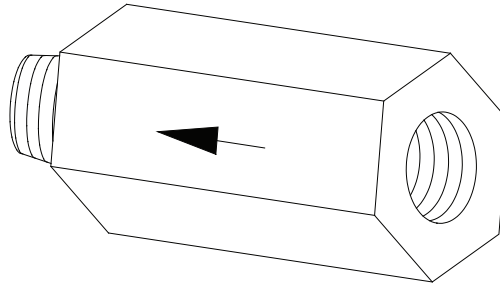

Item #	Part #	Description	Qty
1	400137937	Syphon Check Valve ordered separately	1
1	400137908	Syphon Check Valve ordered with STP	1

CONTROL BOX ASSEMBLY (STP-CBS)

NOTE: Enclosure dimensions: 8.5"H x 5"W x 3"D (215mm x 127mm x 76mm)

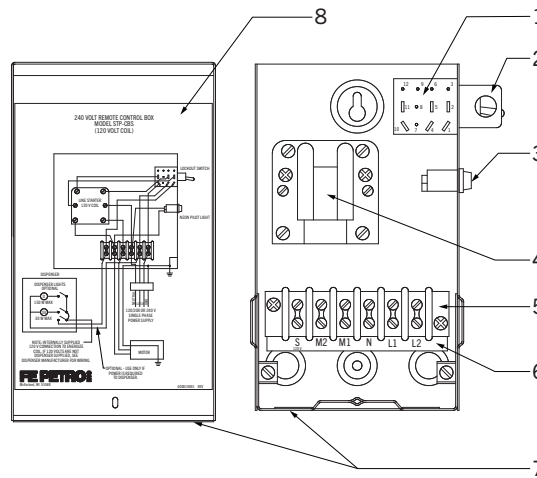

Item #	Part #	Description	Qty
1	400575001	Power Switch (for CBS and CBBS models)	1
2	400574001	Bracket, Power Switch	1
3	400158901	Light Assembly, 120V (CBS)	1
	400158902	Light Assembly, 240V (CBBS)	1
4	400215931	Relay, 30A, 120V	1
	400215933	Relay, 30A, 240V	1
5	400278005	Terminal Strip	1
6	402410001	Label, Terminal Strip (CBS)	1
	402410002	Label, Terminal Strip (CBBS)	1
7	400817901	Cover & Enclosure	1
8	400819001	Wiring Diagram (CBS)	1
	400819002	Wiring Diagram (CBBS)	1

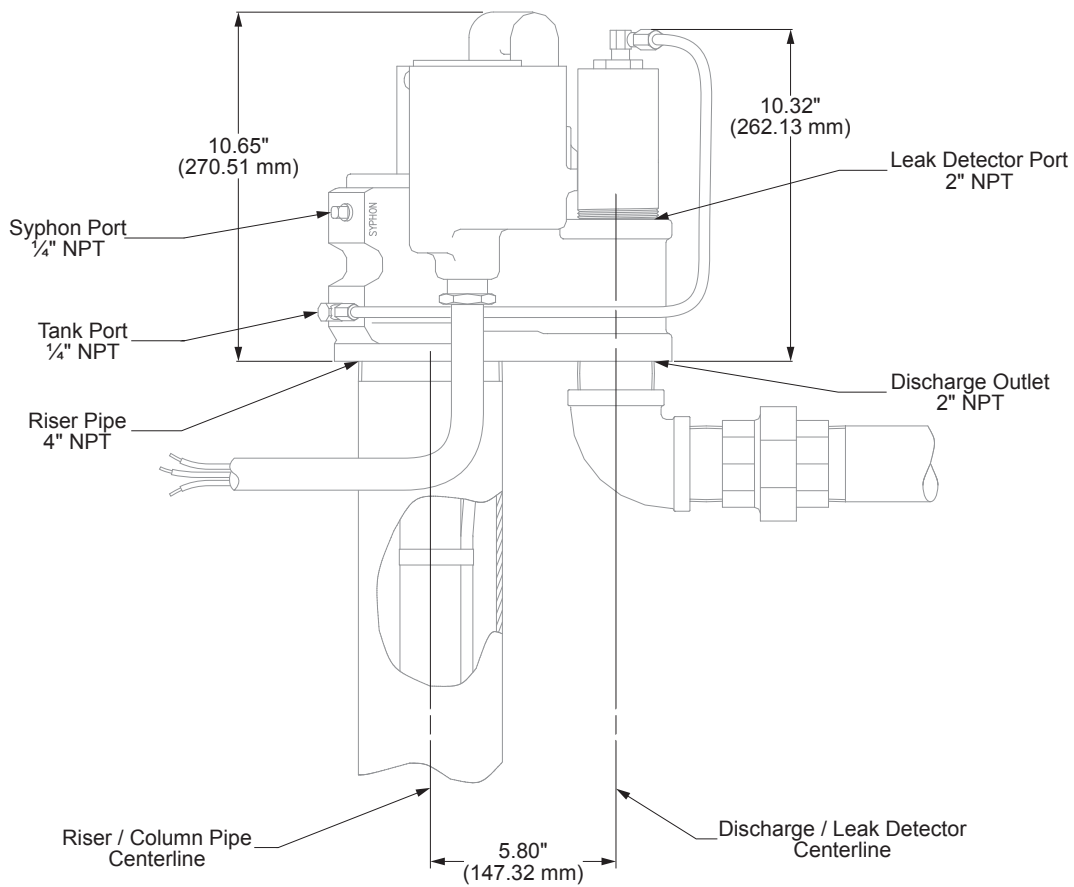
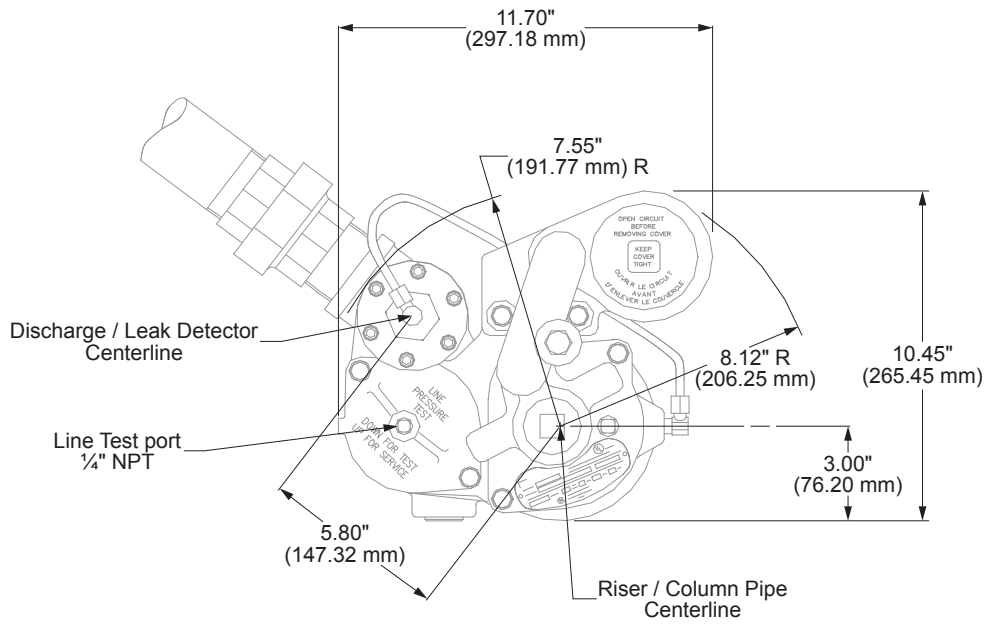

Intentionally Blank

Intentionally Blank

Intentionally Blank

