



Healy Self-Service Nozzles

Models 600, 700, and 800

Main Valve Spring Replacement Instructions

Important Safety Messages

Franklin Fueling Systems (FFS)/Healy equipment is designed to be installed in association with volatile hydrocarbon liquids such as gasoline. Installing or working on this equipment means working in an environment in which these highly flammable liquids may be present. Working in such a hazardous environment presents a risk of severe injury or death if these instructions and standard industry practices are not followed. Read and follow all instructions thoroughly before installing or working on this, or any other related, equipment.

As you read this guide, please be aware of the following symbols and their meanings:

Warning  This symbol identifies a warning. A warning sign will appear in the text of this document when a potentially hazardous situation may arise if the instructions that follow are not adhered to closely. A potentially hazardous situation may involve the possibility of severe bodily harm or even death.

Caution  This is a caution symbol. A caution sign will appear in the text of this document when a potentially hazardous environmental situation may arise if the instructions that follow are not adhered to closely. A potentially hazardous environmental situation may involve the leakage of fuel from equipment that could severely harm the environment.

Warning  **Follow all applicable codes governing the installation and servicing of this product and the entire system. Always lock out and tag electrical circuit breakers while installing or servicing this equipment and any related equipment. A potentially lethal electrical shock hazard and the possibility of an explosion or fire from a spark can result if the electrical circuit breakers are accidentally turned on during installation or servicing. Please refer to the Installation and Owner's Manual for this equipment, and the appropriate documentation for any other related equipment, for complete installation and safety information.**

Warning  **Follow all federal, state and local laws governing the installation of this product and its associated systems. When no other regulations apply, follow NFPA codes 30A and 70 from the National Fire Protection Association. Failure to follow these codes could result in severe injury, death, serious property damage and/or environmental contamination.**

Warning  **Always secure the work area from moving vehicles. The equipment in this manual is usually mounted underground, so reduced visibility puts service personnel working on this equipment in danger from moving vehicles entering the work area. To help eliminate these unsafe conditions, secure the area by using a service truck to block access to the work environment, or by using any other reasonable means available to ensure the safety of service personnel.**

Warning  **Use circuit breakers for multiple disconnect to turn off power and prevent feedback from other dispensers.**

Purpose

The purpose of this instruction is to define the necessary procedures required to replace the main valve spring on Self-Service Nozzles, Models 600/700/800.

Procedure

Follow all applicable safety procedures when removing hose/nozzle components on **operational dispensers**.

Note: Before starting this procedure, squeeze the nozzle lever to make certain there is no gasoline pressure remaining in the hose or nozzle.

1. Secure nozzle in vise or clamp
2. Remove hand warmer



Figure 1: Remove Scuff Guard

3. Carefully peel back the scuff-guard (Figure 1) using flat-blade screwdriver to expose the main valve cap



Figure 2: Loosen Main Cap

- Using a 1-3/8" socket/driver loosen the main valve cap by turning counter-clockwise (figure 2).



Figure 3: Remove Cap

- Remove the cap by hand, keeping pressure on the top of the cap as it is spring-loaded (Figure 3).



Figure 4: Remove Spring

- Remove the original spring being careful not to remove any of the main valve components (Figure 4).

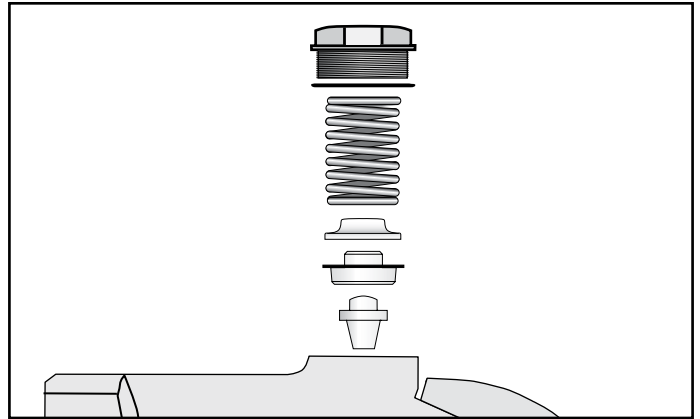

Figure 5: Illustration of Component Order

- If any main valve components come out with the spring, return them to the valve seat in the same order as shown (Figure 5).



Figure 6: Installing New Spring

- Place the new spring on top of the main valve, making sure that the top of the valve is seated properly (Figure 6). The spring coil should fit over the raised section of the valve.

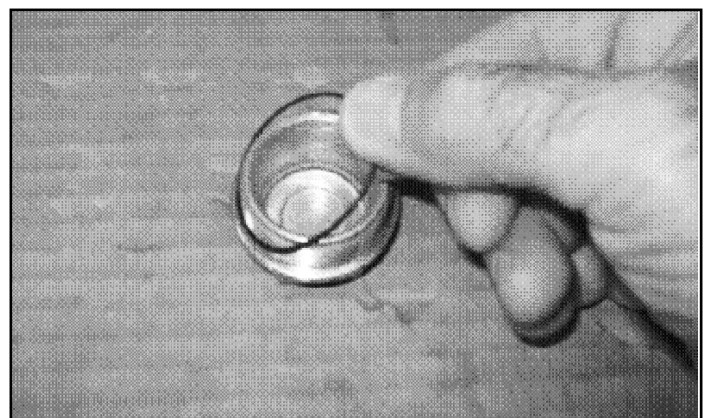

Figure 7: Cap O-ring

- Before installing the main valve cap, replace the O-ring on the cover (Figure 7).

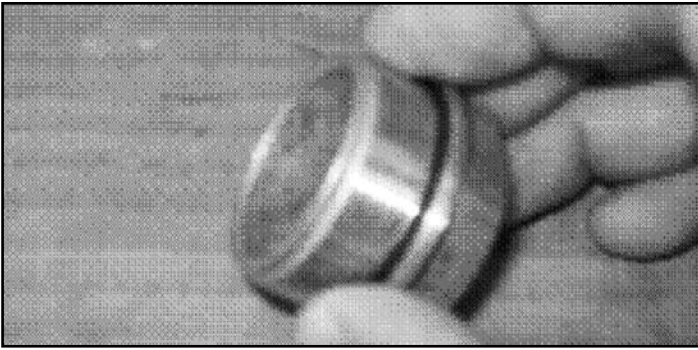

Figure 8: O-ring Installed

10. Make sure the O-ring (Figure 8) is properly seated at the top of the cap threads to avoid damage when installing.



Figure 9: Installing Cap

11. Firmly & evenly push down on the main valve cap while turning it clockwise to engage the threads (Figure 9).

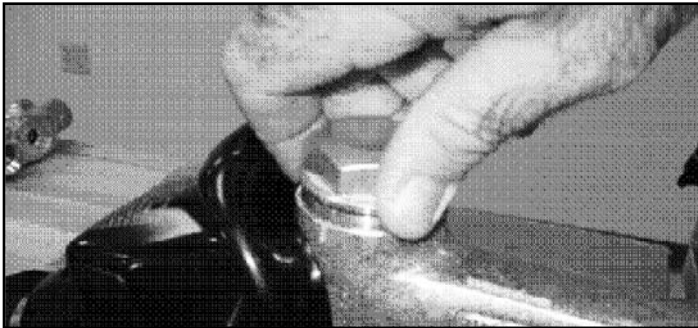

Figure 10: Tighten Cap

12. Hand-tighten the cap until the O-ring seats on the nozzle casting (Figure 10).

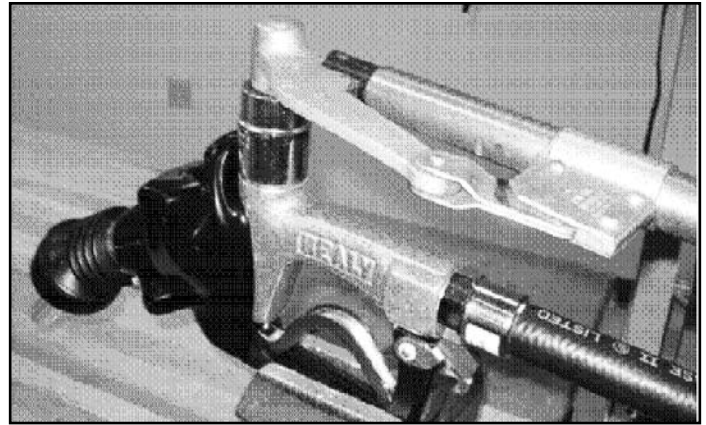

Figure 11: Tighten Cap

13. Using a 1-3/8" socket/driver with a torque indicator, set the main valve cap to 50 ft/lbs (Figure 11).

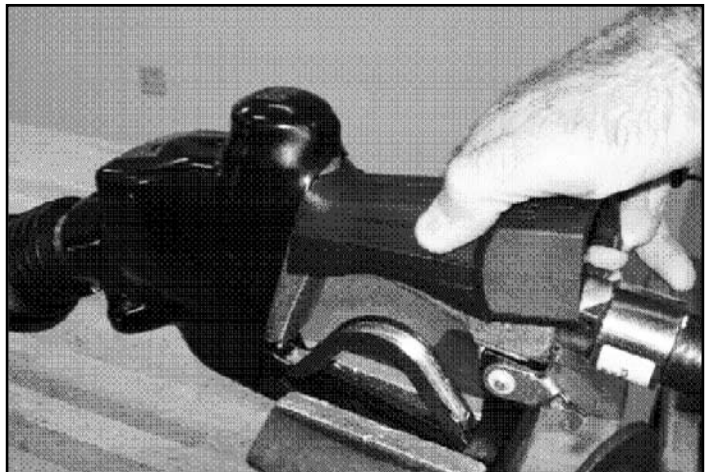

Figure 12: Install Scuff-Guard and Hand warmer

14. Carefully replace scuff-guard (Figure 12).
15. Replace hand warmer (Figure 12).

Note: Nozzle should be authorized, checked for leaks and for proper operation before returning it to service.



Franklin Fueling Systems

www.franklinfueling.com

3760 Marsh Road • Madison, WI 53718, U.S.A.

Tel: +1 608 838 8786 • Fax: +1 608 838 6433

Tel: USA & Canada 1 800 225 9787 • Tel: México 001 800 738 7610

Franklin Fueling Systems GmbH

Rudolf-Diesel-Strasse 20 • 54516 Wittlich, GERMANY

Tel: +49-6571-105-380 • Fax: +49-6571-105-510