

# SBK - Stabilizer Bar Kit

## Installation Instructions

**Warning**  Follow all federal, state and local laws governing the installation of this product and its associated systems. When no other regulations apply, follow NFPA codes 30, 30A and 70 from the National Fire Protection Association. Failure to follow these codes could result in severe injury, death, serious property damage and/or environmental contamination.

1. Check the orientation on all of the shear valves and make sure that there is sufficient space to install the stabilizer bar kits. If there is not enough space to mount multiple stabilizer bar kits, rotate a shear valve and stabilizer bar kit 180 degrees.
2. Connect the mounting plate to the shear valve using three socket head cap screws. See Figure 1.
3. Place two spring nuts into each uni-strut approximately 2½" apart by pushing the nuts in spring first and lengthwise with the opening. Compress the spring and lock the nuts by turning them clockwise into the uni-strut. See Figure 2.
4. Mount the stabilizer bar to the spring nuts (in four places) and hand-tighten the bolts to hold the bracket in place and to allow for final positioning.
5. Loosely secure the mounting bracket to the stabilizer bar with the bolts and washers (front & back) provided.

**Note:** Be sure to secure the mounting bracket to the *flat side* of the stabilizer bar.

6. Position the emergency shutoff valve at the optimum height and center it to enable it to properly function with the shear portion of the valve.
7. Tighten all of the bolts.

**Warning**  The emergency shutoff valve must be mounted securely or it may not function as intended.

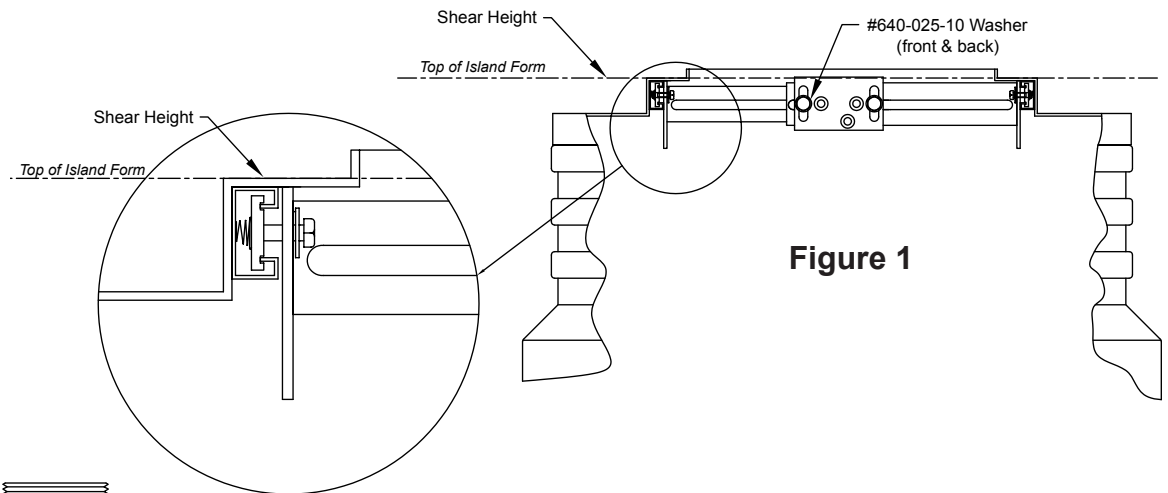

Figure 1

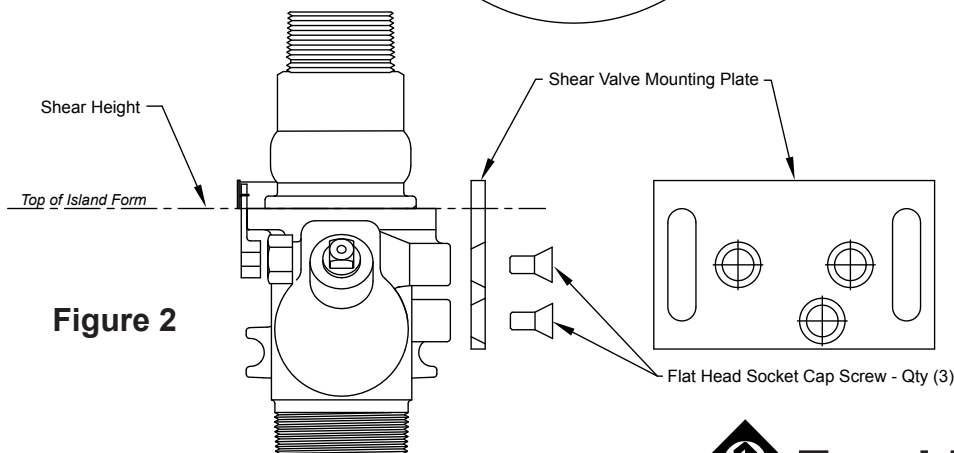

Figure 2



**Franklin Fueling Systems**

3760 Marsh Road • Madison, WI 53718 U.S.A.  
Tel: +1 608 838 8786 • Fax: +1 608 838 6433 • www.franklinfueling.com  
Tel: USA & Canada 1 800 225 9787 • Tel: México 001 800 738 7610